



Beta Three



Meline Series **S2-III**
Professional Active Performance System

User Manual





UM-Meline S2-III-20160122 ver A



SAFETY INSTRUCTIONS

PLEASE READ THIS MANUAL FIRST

Thank you for a buying β_3 product. Read this manual first as it will help you operate the system properly. Please keep this manual for future reference.

⚠ WARNING: *This product must be installed by professionals. When using hanging brackets or rigging other than those supplied with the product, please ensure they comply with the local safety codes.*

	CAUTION RISK OF ELECTRICAL SHOCK DO NOT OPEN	
CAUTION: TO REDUCE THE RISK OF ELECTRIC SHOCK, DO NOT REMOVE COVER (OR BACK). NO USER-SERVICABLE PARTS INSIDE. REFER SERVICING TO QUALIFIED PERSONNEL.		

	AVIS RISQUE DE CHOC ÉLECTRIQUE NE PAS OUVRIR	
ATTENTION : POUR RÉDUIRE LE RISQUE DE DÉCHARGE ÉLECTRIQUE, NE RETIREZ PAS LE COUVERCLE (OU L'ARRIÈRE). IL NE SE TROUVE À L'INTÉRIEUR AUCUNE PIÈCE POUVANT ÊTRE RÉPARÉE PAR L'USAGER. S'ADRESSER À UN RÉPARATEUR COMPÉTENT.		

 *The exclamation point within an equilateral triangle is intended to alert you to the presence of important operating and servicing instructions.*

⚠ ATTENTION: *Don't refit the system or spare parts without being authorized as this will void the warranty.*

⚠ WARNING: *Don't place naked flames (such as candles) close to the equipment.*

1. Read the instruction manual first before using this product.
2. Please keep this manual for future reference
3. Pay attention to all warnings.
4. Obey all operating instructions.
5. Do not expose this product to rain or moisture.
6. Clean this equipment with a dry cloth.
7. Do not block any ventilation openings. Install according to manufacturer's instructions .
8. Do not install this product near any heat source, such as a, heater, burner, or any other equipment with heat radiation .
9. Only use spare parts supplied by the manufacturer.
10. Pay attention to the safety symbol on the outside of the cover.

CONTENT

INTRODUCTION	3
Features	3
Description	3
Applications	3
AMPLIFIER MODULE	4
Amplifier Module	4
INSTALLATION	5
Mounting Accessories	5
Installation Reference	5
TECHNICAL SPECIFICATION	6
Technical Sheet	6
Frequency Response Curve and THD Curve	6
2D Dimension	7

Meline Series S2-III

Professional Active Performance System

Features

- Compact, portable and eye catching design.
- System is 1.8M high to deliver full, natural sound.
- 12 × 2.75" full range and 2 × 25mm Silk dome tweeter vertical column speakers to ensure smooth sound coverage.
- Bi-amp module including DSP.
- Exclusive CLIK together connections, no cables required.
- Handle on back of subwoofer.
- Carry bags for system, ease of transportation.

Description

3[®] Meline S2-III is a performance sound reinforcement system designed for musicians, meeting room presentation, DJ's etc for an audience up to 300. The three piece system is designed for quick and easy setup with new click together interconnecting speakers. The amplifier module is housed within the subwoofer. This bi-amp module includes DSP to enable superior performance.

The active 3-way column speaker system Meline S2-III can be used for various PA applications. The individual components of the Meline S2-III (1 subwoofer module, 2 column modules) can be connected so that the Meline S2-III is also ideally suited for mobile applications. Two class D amplifiers, each with a power of 400W RMS, are available for the low-frequency and the mid-high frequency ranges.

Two audio units and two microphones can be connected to the 4-channel mixer unit. For sound adjustment and frequency splitting, the audio signals pass a digital signal processor (DSP) that also includes a signal limiter.

Applications

- Church
- Auditorium
- Conference room
- Small performance
- Multifunctional hall



Amplifier Module

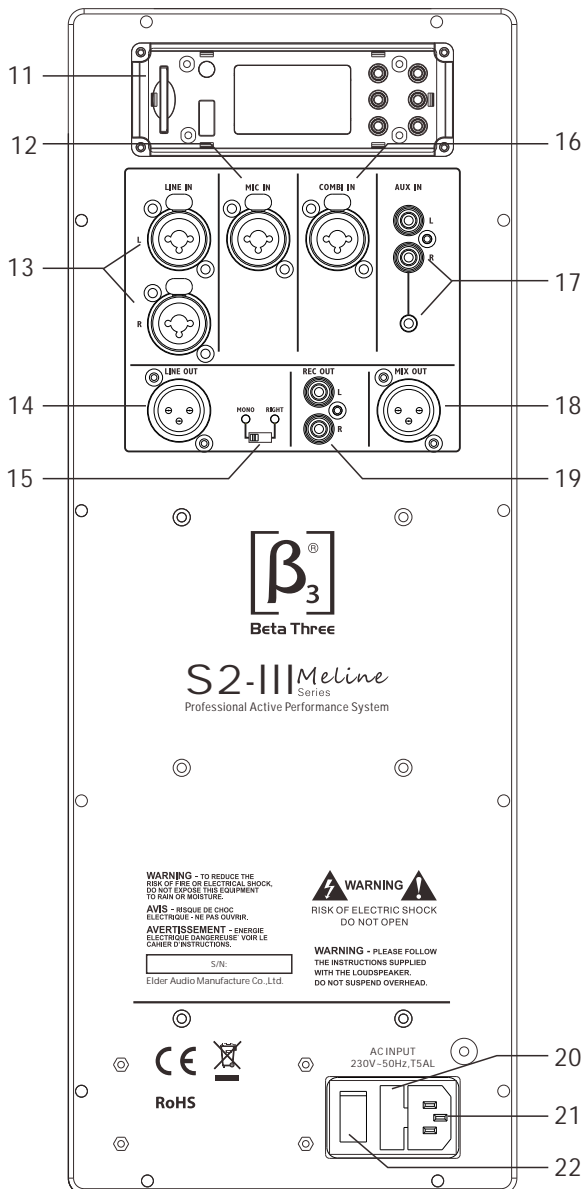
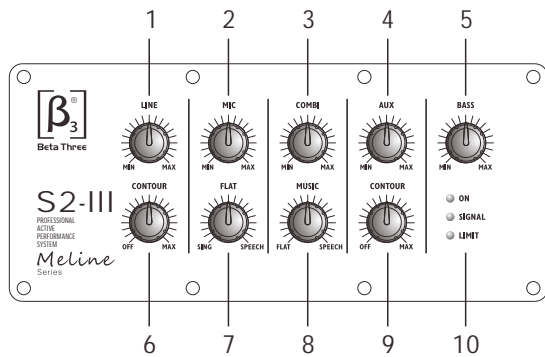

1. Volume control for the input LINE IN(12)
2. Volume control for the input MIC IN(11)
3. Volume control for the input COMBI IN(15)
4. Volume control for the input AUX IN(16)
5. Control to adjust the strength of the low frequencies radiated by the subwoofer
6. Control CONTOUR to define the level of the aurally compensated sound correction for the input LINE IN(12)
7. Equalizer control for the signal of the input MIC IN(11), continuously adjustable between vocals(SING), neutral (FLAT)and speech
8. Equalizer control for the signal of the input COMBI IN(15), continuously adjustable between neutral(FLAT),music and speech
9. Control CONTOUR to define the level of the aurally compensated sound correction for the input AUX IN(16)
10. LED indicators
 - ON = Power indicator
 - SIGNAL = Signal indicator
 - LIMIT = Limiter indicator: Lights up when the signal level is too high;the limiter will reduce the signal level to protect the speaker.
11. MP3 music player module
12. Input MIC IN(combined 6.3mm jack/XLR,bal.)to connect a microphone
13. Stereo input LINE IN(combined 6.3mm jacks/XLR,bal.)to connect a signal source with line output level (e.g.mixer,CD/MP3 player)
14. Output LINE OUT(XLR,unbal.)
At this output,the signal of the input LINE IN(12)is available; either as a mono signal or only the signal of the right channel, can be selected by means of the selection switch(14).
15. Switch to select the operating mode
MONO = The speaker column reproduces the signal of the input LINE IN(12)monophonically;the monophonic input signal is available at the output LINE OUT(13).
RIGHT = The speaker column reproduces the left channel of the input LINE IN;the input signal of the right channel is available at the output LINE OUT.
16. Mono input COMBI IN(combined 6.35mm jack/XLR,bal.)to connect a microphone
17. Stereo input AUX IN(RCA jacks and 3.5mm jack,unbal.)to connect a signal source with line output level
18. Output MIX OUT(XLR,unbal.)to send the mixed mono signal to an additional amplifier,for example
19. Output REC OUT(RCA)to connect a recorder
At this output,the mixed stereo signal is available.
20. Support for the mains fuse
Always replace a blown fuse by one of the same type.
21. Mains jack for connection to a socket(230V~50Hz)by means of the mains cable provided
22. Power switch

Installation Accessories(Optional)

1.Meline S2-II BAG

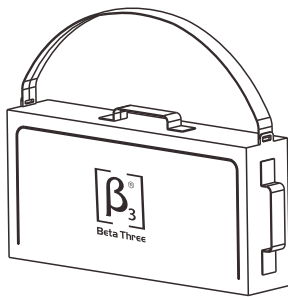
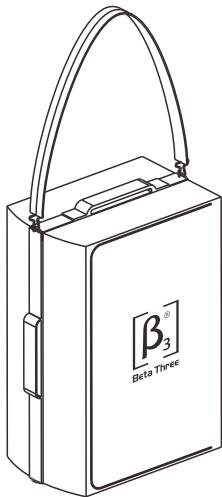

2.Meline S2-II EXT

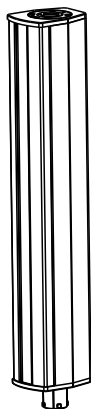

Installation Reference

1. Place the subwoofer module on an even, horizontal surface (floor).
2. Start with the column module where a 6.35mm jack is located on the upper side. Place the column module—turned by approx. 20° to the left—onto the connector of the subwoofer module and then turn it to the right stop so that it is firmly engaged.
3. Proceed in the same way to connect the second column module to the first one.
4. If the tweeters located in the centre of the connected columns do not have the optimal height (ear's height), use the adapter piece Meline S2-II EXT (available as an option) to increase the height of the column modules.

Reference A

Reference B

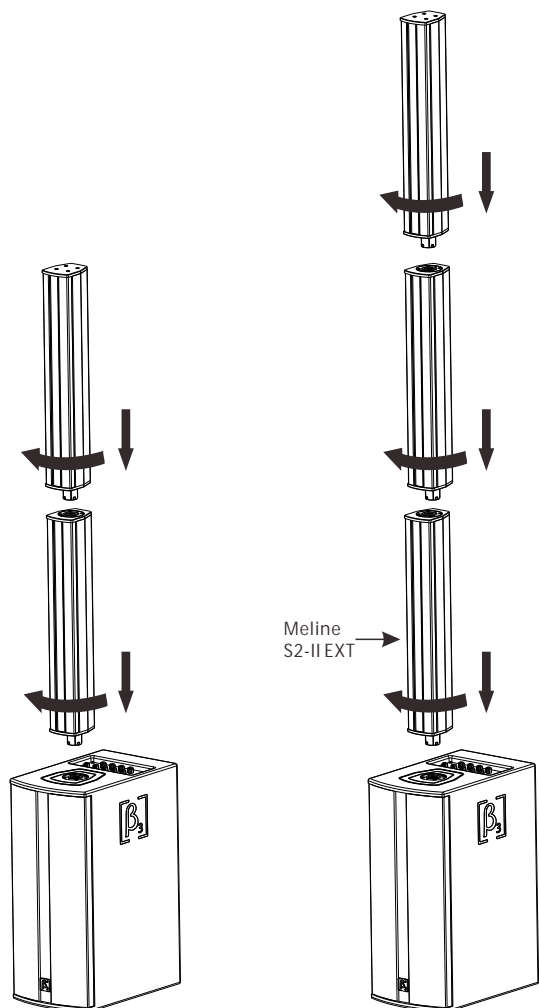

Specification

Frequency response(-3dB):	45Hz-20kHz
Max.SPL:	113dB/119dB(PEAK)
Dispersion(H x V):	90° x 40°
Transducer:	2 x 8" Woofer, 12 x 2.75" Midrange Unit 2 x 25mm Silk dome tweeter
Power:	LF:200W,MF:180W, HF:30W
Rated impedance:	4 Ohms
Connector:	XLR for input, XLR for output
Input:	Three channel (MIC/COMBI/LINE) balanced input(XLR and 6.35mm jack) One channel (AUX) unbalanced input(RCA and 3.5mm jack)
Input impedance(line):	20kohm balanced input, 10kohm unbalanced input
Input level:	LINE IN: 775mVrms, AUX IN: 200mVrms MIC IN: 20mVrms, COMBI IN: 40mVrms
Input overloading level:	LINE IN: 3.5Vrms, AUX IN: 2Vrms MIC IN: 200mVrms, COMBI IN: 400mVrms
Wire connection:	pin 1: ground; pin2: signal +; pin3: signal -
Heat radiation:	Forced air-cooled drives
Power cable:	PowerCon, three pins
Safety voltage range:	AC 220V-230V~50Hz/60Hz
Amplifier power output:	800W
Cabinet:	Plywood,column loudspeaker
Handle:	1 x Wooden handles
Painting:	Cabinet coated by Polyurethane paint; grille is powder coated
Cabinet dimension(W x D x H):	250 x 400 x 1726mm(9.8 x 15.7 x 68.0in)
Packing dimension(W x D x H):	615 x 355 x 705mm(24.2 x 14.0 x 27.8in)
Net weight:	23.5kg(51.7 lbs)
Gross weight:	25.5kg(56.1 lbs)

Frequency response curve & THD curve

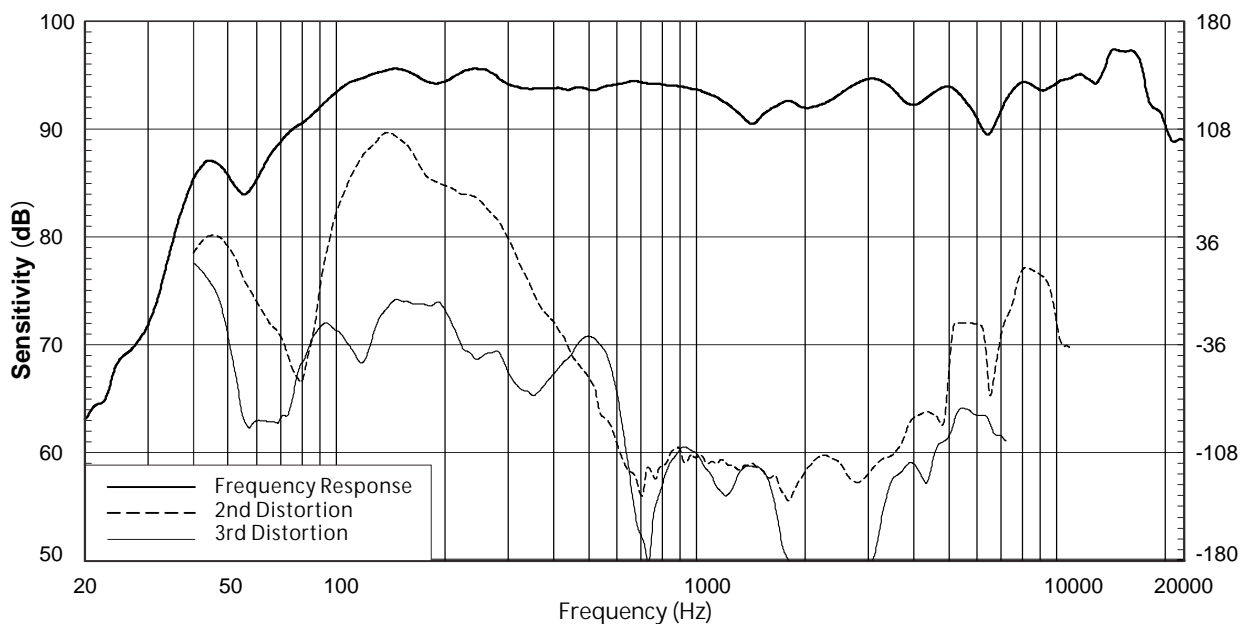

2D Dimension

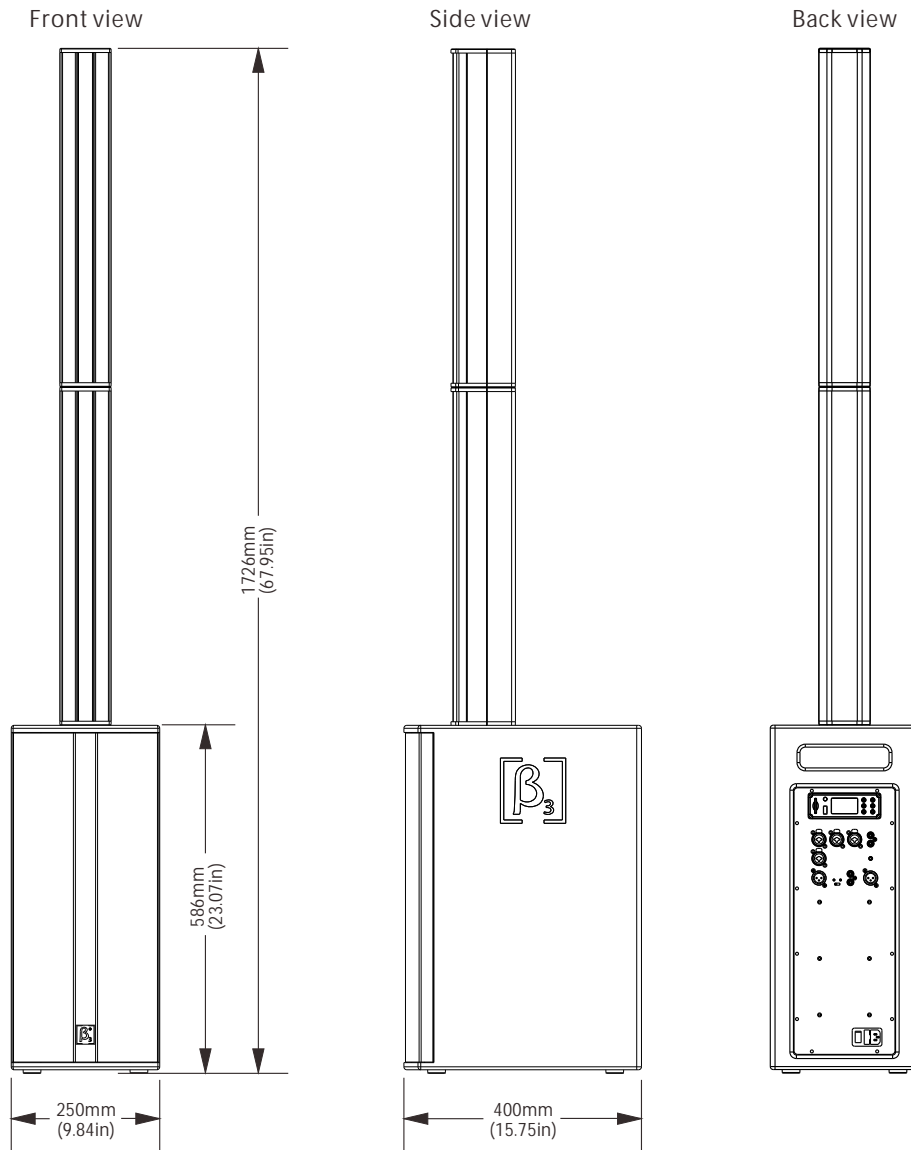

Meline S2-II EXT:

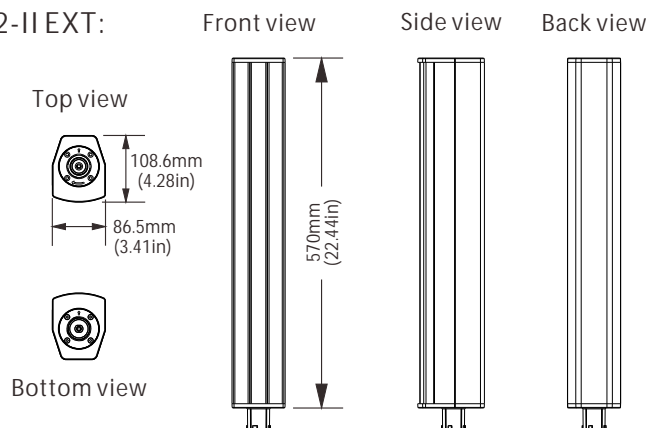

Notes:



Beta Three