

SOUNDCHOICE
PROAUDIO

www.scpaudio.com

5-ZONE PAGING MICROPHONE STATION

MODEL:RWP5



Warning: Before attempting to connect, operate or adjust this Paging Station, please read these instructions completely and carefully and save this Manual

IMPORTANT SAFETY INSTRUCTIONS

1. Read these instructions - All the safety and operating instructions should be read before this product is operated.
2. Keep these instructions - The safety and operating instructions should be retained for future reference.
3. Heed all warnings - All warnings on the appliance and in the operating instructions should be adhered to.
4. Follow all instructions - All operating and use instructions should be followed.
5. Do not use this apparatus near water - The appliance should not be used near water or moisture - for example, in a wet basement or near a swimming pool, and the like.
6. Clean only with dry cloth.
7. Do not block any ventilation openings. Install in accordance with the manufacturer's instructions.
8. Do not install near any heat sources such as radiators, heat registers, stoves, or other apparatus (including amplifiers) that produce heat.
9. Do not defeat the safety purpose of the polarized or grounding plug. A polarized plug has two blades with one wider than the other. A grounding plug has two blades and a third grounding prong. The wide blade or the third prong is provided for your safety. If the provided plug does not fit into your outlet, consult an electrician for replacement of the obsolete outlet.
10. Protect the power cord from being walked on or pinched particularly at plugs, convenience receptacles, and at the point where they exit from the apparatus.
11. Only use attachments/accessories specified by the manufacturer.
12. Use only with the cart, stand, tripod, bracket, or table specified by the manufacturer, or sold with the apparatus. When a cart is used, use caution when moving the cart/apparatus combination to avoid injury from tip-over. 
13. Unplug the apparatus during lightning storms or when unused for long periods of time.
14. Refer all servicing to qualified service personnel. Servicing is required when

- the apparatus has been damaged in any way, such as power supply cord or plug is damaged, liquid has been spilled or objects have fallen into the apparatus the apparatus has been exposed to rain or moisture, does not operate normally, or has been dropped.
15. Please keep the unit in a good ventilation environment.
16. **WARNING:** To reduce the risk of fire or electric shock, do not expose this apparatus to rain or moisture. The apparatus shall not be exposed to dripping or splashing and that no objects filled with liquids, such as vases, shall not be placed on apparatus.
17. **WARNING:** The mains plug or appliance inlet is used as disconnect device, the disconnect device shall remain readily operable.
18. Power Sources – This product should be operated only from the type of power source indicated on the rating label. If you are not sure of the type of power supply to your home, consult your product dealer or local power company. For products intended to operate from battery power, or other sources, refer the operating instructions.
19. Safety Check – Upon completion of any service or repairs to this product, ask the service technician to perform safety checks to determine that the product is in proper operating condition.
20. Don't touch conductive parts of output terminals to prevent hazardous electrical shock. The external wiring connected to the terminals requires installation by an instructed person or the used of ready-made leads or cords.
21. This equipment is for commercial & professional use only.
22. This product is in compliance with EU WEEE regulations. Disposal of end of life product should not be treated as municipal waste. Please refer to your local regulations for instructions on proper disposal of this product. 
23. To prevent hazardous electrical shock, do not touch the conductive parts of the output terminals. The external wiring connected to the terminals requires installation by an qualified technician or the use of ready made leads or cords.
24. Please locate the apparatus at places nearby power socket for quick power disconnection in emergency.



Protective earthing terminal. The apparatus should be connected to a mains socket outlet with a protective earthing connection.



This lightning flash is intended to alert the user to the presence of non-insulated "dangerous voltage" on the output terminals that may be of sufficient magnitude to constitute a risk of electric shock. The external wiring connected to the terminals requires installation by an instructed person or the used of ready-made leads or cords.



CAUTION

**RISK OF ELECTRIC SHOCK
DO NOT OPEN**



CAUTION: To reduce the risk of electric shock, do not remove any cover. No user-serviceable parts inside. Refer servicing to qualified service personnel only.



The lightning flash with arrowhead symbol within the equilateral triangle is intended to alert the user to the presence of uninsulated "dangerous voltage" within the product's enclosure that may be of sufficient magnitude to constitute a risk of electric shock.



The exclamation point within the equilateral triangle is intended to alert the user to the presence of important operation and maintenance (servicing) instructions in the literature accompanying this appliance.

CAUTION: To prevent electric shock, do not use this polarized plug with an extension cord, receptacle or other outlet unless the blades can be fully inserted to prevent blade exposure.

Table of Content

Introduction -----	2
Features -----	2
Controls-----	3
Connections -----	4
Operations-----	4
Block Diagrams -----	5
Specifications -----	6

Introduction

Welcome

Congratulation and thank you for the purchasing RWP5 microphone paging station. These paging stations are designed to provide and to produce the best and highest quality audio at an affordable price. We wish you great enjoyment and satisfaction when using your paging station for your installation.

Unpacking and Installation

Although not complicated to install nor difficult to operate your paging station, a few minutes of your time is required to read this manual for a properly wired installation and becoming familiar with its features and how to use them. Please take care in unpacking your paging station and do not discard the carton and other packing materials. They may be needed when moving or required if it ever becomes necessary to return for service. Never install near a radiator, in front of heating vents, to direct sun light, in excessive humid or dusty location to avoid damage and to guaranty a long reliable operation.

Connect your paging station with the system components according to the description on the following pages.

Features

The RWP5 desktop goose neck paging microphone is comprehensive, all-in-one paging solution for commercial and industrial applications. This unit provides all necessary features in a simple building-block format.

- * Built in phantom power for condenser microphone with XLR jack.
- * Wide range input level.
- * Locking switch.
- * Easy installation with only one UPT CAT-5 cable for all of controls and power.
- * Up to 5 individual zone with pre-announcement chime.
- * Low distortion and low noise level.
- * Compact size and lightweight.
- * Ideal for commercial and industrial use.

Controls

FRONT PANEL

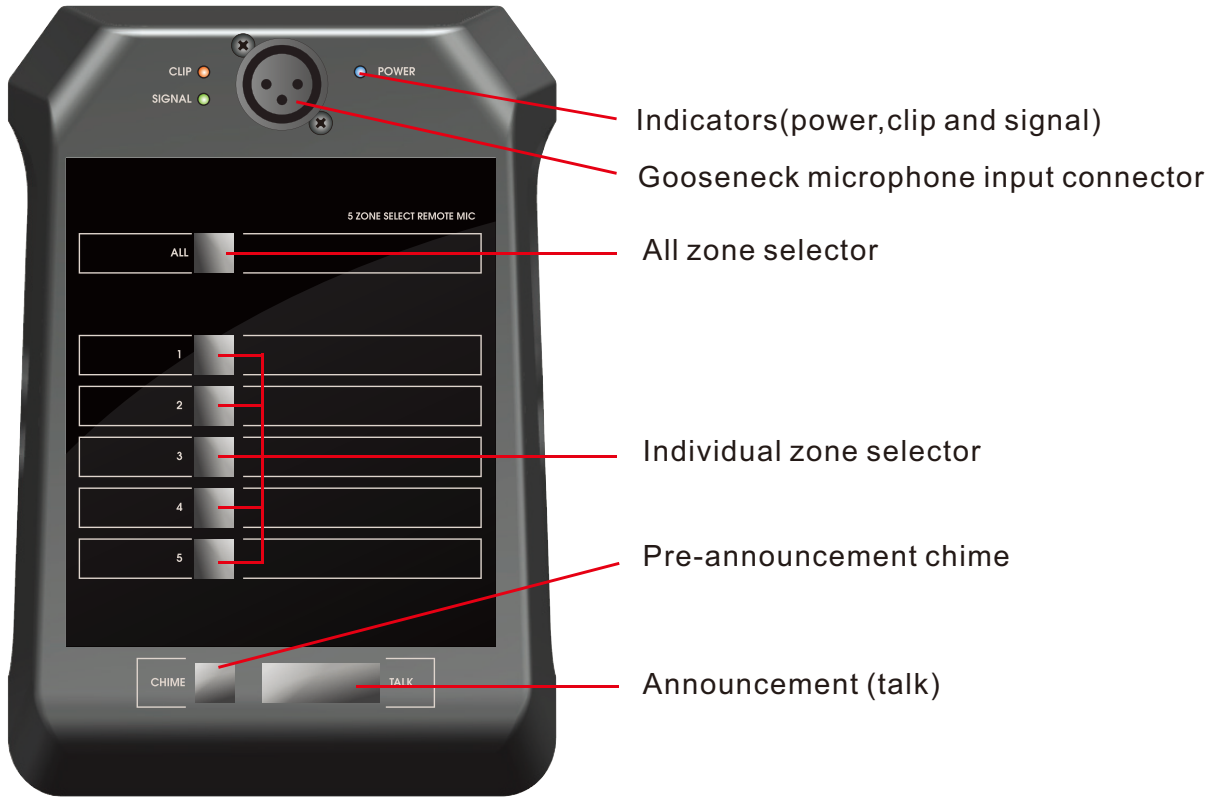

[Figure 1.1 Front panel]

Rear Panel



[Figure 1.2 Rear panel]

Connections

RWP5 should only be connected to MA Series mixer amplifier .
RJ45 PIN assign is as follows.

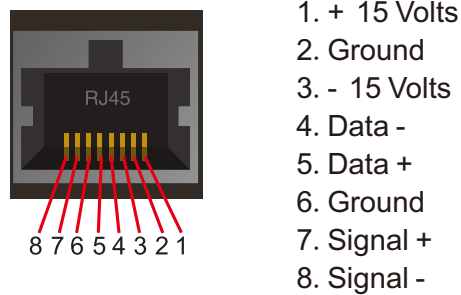

[Figure 2.1 UTP CAT-5 cable connection]

Operations

1. Press zone selection button Z1 to Z5 for individual zone announcement.
2. The selected zone LED will turn on. If you want to remove selected zone, press same zone button again.
3. "CHIME" button plays pre-announcement chime.
4. Press and hold the "TALK" button while you announce to selected zone.
5. All of zone selection buttons don't operate when the locking switch is in the "LOCK" position.
6. Output level can be controlled by rear volume.

Block diagram

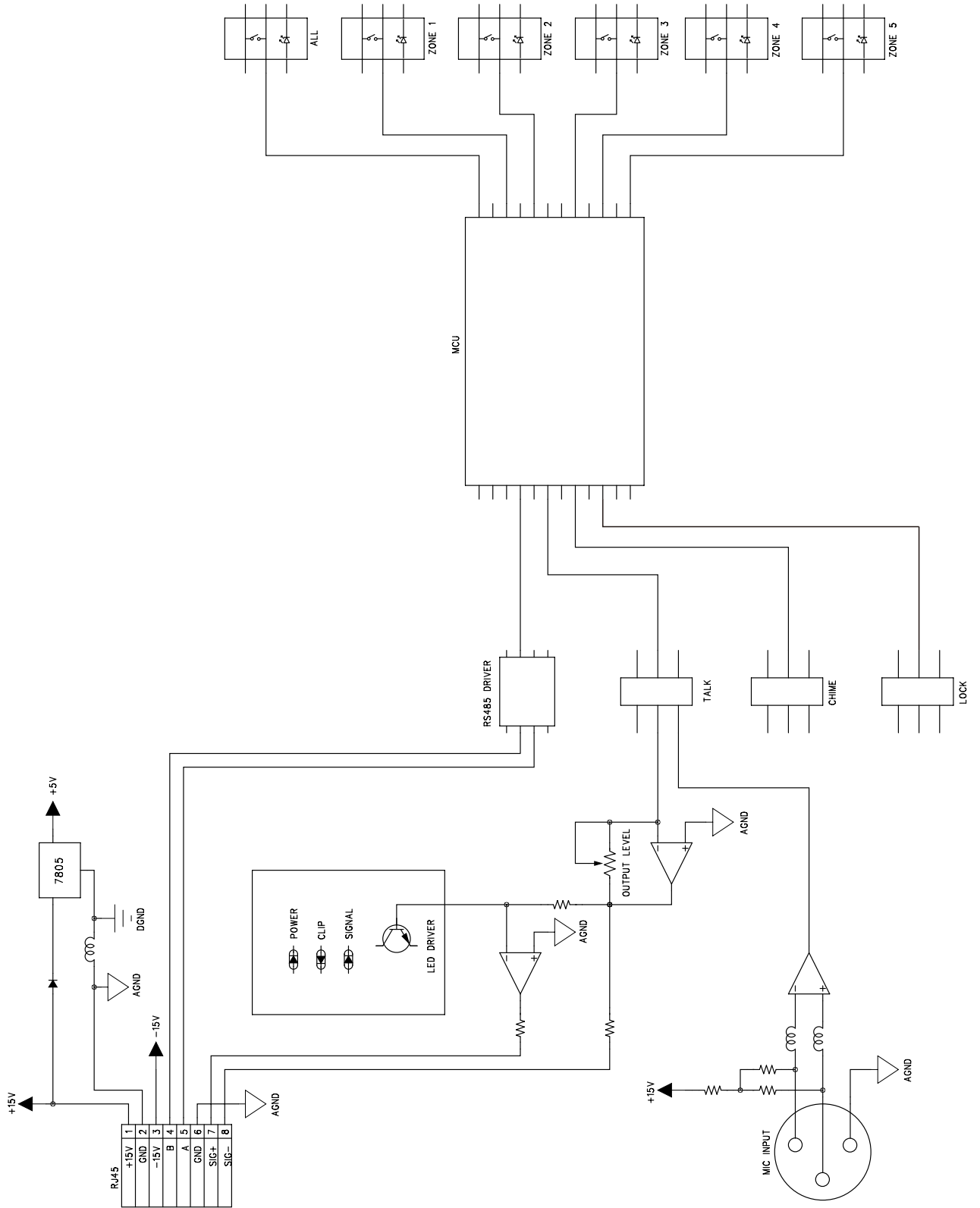

Specifications

Performance	
Input Sensitivity	-60dB ± 3dB / 600Ω Balanced
Frequency Response	45Hz ~15kHz / ±1dB
Signal to Noise Ratio	Less than 90dB
Rated Output Level	0dB / 600Ω Balanced
Total Harmonic Distortion(THD) at 1kHz rated output	Less than 0.1%
Operating Temperature/Humidity at non-condensing	0°~40°C at 95% humidity
Construction	
Dimensions (Width/Height/Depth)	140mm X 60mm X 205mm
Net Weight	0.9kg

Necessary modifications are carried out without notice.