

SOUNDCHOICE
PROAUDIO

www.scpaudio.com

Public Address Pre Amplifier

Commercial

MODEL:M804

Warning: Before attempting to connect, operate or adjust this mixer, please read these instructions completely and carefully and save this Manual

IMPORTANT SAFETY INSTRUCTIONS

1. Read these instructions - All the safety and operating instructions should be read before this product is operated.
2. Keep these instructions - The safety and operating instructions should be retained for future reference.
3. Heed all warnings - All warnings on the appliance and in the operating instructions should be adhered to.
4. Follow all instructions - All operating and use instructions should be followed.
5. Do not use this apparatus near water - The appliance should not be used near water or moisture - for example, in a wet basement or near a swimming pool, and the like.
6. Clean only with dry cloth.
7. Do not block any ventilation openings. Install in accordance with the manufacturer's instructions.
8. Do not install near any heat sources such as radiators, heat registers, stoves, or other apparatus (including amplifiers) that produce heat.
9. Do not defeat the safety purpose of the polarized or grounding plug. A polarized plug has two blades with one wider than the other. A grounding plug has two blades and a third grounding prong. The wide blade or the third prong is provided for your safety. If the provided plug does not fit into your outlet, consult an electrician for replacement of the obsolete outlet.
10. Protect the power cord from being walked on or pinched particularly at plugs, convenience receptacles, and at the point where they exit from the apparatus.
11. Only use attachments/accessories specified by the manufacturer.
12. Use only with the cart, stand, tripod, bracket, or table specified by the manufacturer, or sold with the apparatus. When a cart is used, use caution when moving the cart/apparatus combination to avoid injury from tip-over. 
13. Unplug the apparatus during lightning storms or when unused for long periods of time.
14. Refer all servicing to qualified service personnel. Servicing is required when

- the apparatus has been damaged in any way, such as power supply cord or plug is damaged, liquid has been spilled or objects have fallen into the apparatus, the apparatus has been exposed to rain or moisture, does not operate normally, or has been dropped.
15. Please keep the unit in a good ventilation environment.
 16. **WARNING:** To reduce the risk of fire or electric shock, do not expose this apparatus to rain or moisture. The apparatus shall not be exposed to dripping or splashing and that no objects filled with liquids, such as vases, shall not be placed on apparatus.
 17. **WARNING:** The mains plug or appliance inlet is used as disconnect device, the disconnect device shall remain readily operable.
 18. Power Sources – This product should be operated only from the type of power source indicated on the rating label. If you are not sure of the type of power supply to your home, consult your product dealer or local power company. For products intended to operate from battery power, or other sources, refer the operating instructions.
 19. Safety Check – Upon completion of any service or repairs to this product, ask the service technician to perform safety checks to determine that the product is in proper operating condition.
 20. Don't touch conductive parts of output terminals to prevent hazardous electrical shock. The external wiring connected to the terminals requires installation by an instructed person or the used of ready-made leads or cords.
 21. This equipment is for commercial & professional use only.
 22. This product is in compliance with EU WEEE regulations. Disposal of end of life product should not be treated as municipal waste. Please refer to your local regulations for instructions on proper disposal of this product. 
 23. To prevent hazardous electrical shock, do not touch the conductive parts of the output terminals. The external wiring connected to the terminals requires installation by an qualified technician or the use of ready made leads or cords.
 24. Please locate the apparatus at places nearby power socket for quick power disconnection in emergency.



Protective earthing terminal. The apparatus should be connected to a mains socket outlet with a protective earthing connection.



This lightning flash is intended to alert the user to the presence of non-insulated "dangerous voltage" on the output terminals that may be of sufficient magnitude to constitute a risk of electric shock. The external wiring connected to the terminals requires installation by an instructed person or the used of ready-made leads or cords.



CAUTION

**RISK OF ELECTRIC SHOCK
DO NOT OPEN**



CAUTION: To reduce the risk of electric shock, do not remove any cover. No user-serviceable parts inside. Refer servicing to qualified service personnel only.



The lightning flash with arrowhead symbol within the equilateral triangle is intended to alert the user to the presence of uninsulated "dangerous voltage" within the product's enclosure that may be of sufficient magnitude to constitute a risk of electric shock.



The exclamation point within the equilateral triangle is intended to alert the user to the presence of important operation and maintenance (servicing) instructions in the literature accompanying this appliance.

CAUTION: To prevent electric shock, do not use this polarized plug with an extension cord, receptacle or other outlet unless the blades can be fully inserted to prevent blade exposure.

Table of Contents

Introduction	2
Features	3
Front panel controls	4
Rear panel controls	6
Block diagram	8
Specifications	9

Introductions



Welcome

Congratulation and thank you for the purchasing M804, a multi-function commercial mixer. These mixer are designed to provide and to produce the best and highest quality audio at an affordable price. We wish you great enjoyment and satisfaction when using your mixer, whether you are an installation, or reinforcement engineer.

Unpacking and Installation

Although it is neither complicated to install nor difficult to operate unit, a few minutes of your time is required to read this manual for a properly wired installation and becoming familiar with its many features and how to use them. Please take care in unpacking your mixer and do not discard the carton and other packing materials. They may be needed when moving or required if it ever becomes necessary to return for service. Never install near a radiator, in front of heating vents, to direct sun light, in excessive humid or dusty location to avoid damage and to guaranty a long reliable operation.

Connect your unit with the system components according to the description on the following pages.

Features

•Controls

- Front : 4 Mic/Line Input Level(CH1-4) with 3-band EQ and output zone selector switches.
 - 4 Line Input Level (CH5-8) with output zone selector switches.
 - Output Level control with 2 Tone control and Mute switch.
 - Monitor Level control with output zone selector switches.
- Rear : 8 Gain control for each input.
 - Talkover switch for Ch1.
 - Phantom Power switches for CH1 and CH2-4.

•Connectors

- 4 XLR Electronically Balanced jack and 1/4" phone jack for CH1-4 input.
- 4 1/4" phone jack and RCA jack for CH5-8 input.
- RJ45 jack for Remote music source input and remote mic input.
- Euro Block for output.
- Four individual external mute and all mute interface.

•Indicators:

- Power, SIG, CLIP for each input channel and SIG, -20dB, -10dB, 0dB, CLIP, for each output channel.

Front Panel Controls

FRONT PANEL

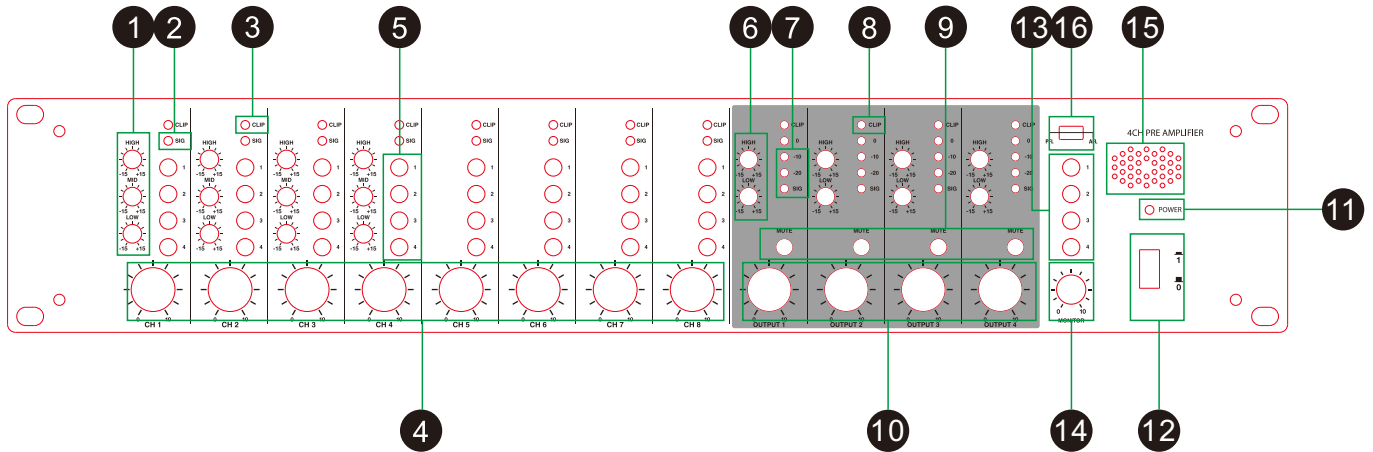

1. INPUT CHANNEL EQUALIZE CONTROLS

These controls allow to equaliza the input signal from -12dB to +12dB at 80Hz(LOW),2.5kHz(MID) and 12.5kHz(HIGH) for CH1~CH4.

2. SIGNAL INDICATORS

These indicators show current input signal on each of the input channels.

3. PEAK INDICATORS

These indicators warn against overload on the each input channels. Please adjust the TRIM on the rear panel when PEAK indicators are flickering for best performance.

4. INPUT CHANNEL VOLUME

These allow to adjust for each input level adjustment

5. OUTPUT CHANNEL SELECTORS

These selectors to route input channel signals to output channels

6. OUTPUT CHANNEL EQ CONTROLS

Output channels have two band equalizer which is adjustable over a wide range as follow.
HIGH : ± 15 dB at 12KHz / LOW : ± 15 dB at 80Hz

7. OUTPUT LEVEL METER

These indicators show current output level.

8. CLIP INDICATORS

These indicators warn against overload on the each output chan-nels. Please adjust the VOLUME control when CLIP indicators are flicking for best performance.

9. MUTE SWITCH

These buttons allow to mute each output channels.

10. OUTPUT VOLUME

These faders allow to adjust the level of each output channels.

11. POWER INDICATOR

This indicator lights when power switch is turned on.

12. POWER SWITCH

This button is power on/off switch.

13. MONITOR SWITCH

These switches allow you to monitor each output channel through monitor speaker.

14. MONITOR OUTPUT CONTROL

This control allow to adjust the level of monitor speaker.

15. MONITOR SPEAKER

16.PFC/ATL SELECTOR

This control allow you to select monitor before or after master volume.

Rear Panel Controls

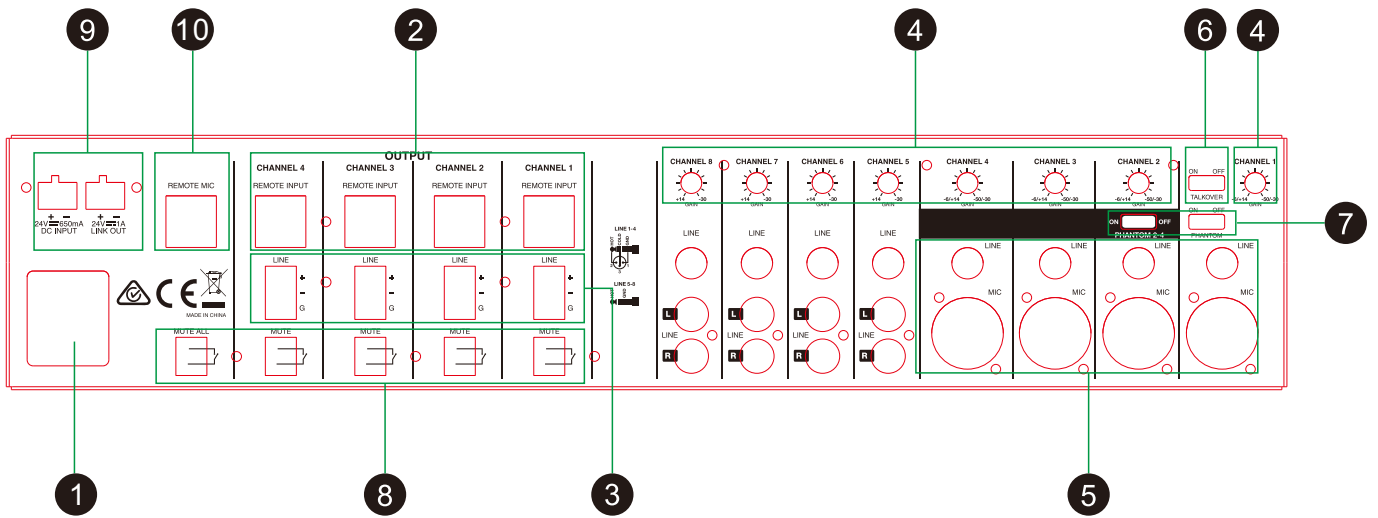

1. AC POWER INPUT CONNECTOR

A correct capacity fuse and power cable should always be used. Please make sure the value of fuse before replacing.

2. REMOTE INPUT

The RJ45 connector allows connection with RWP1 (wall control panel) for adjusting volume and inserting music source of remote area.



3. LINE OUTPUTS

These LINE output blocks can be connected to the input of a power amplifier.

4. TRIM CONTROLS

These controls allow to accept variable input level. They have 44dB adjustable range as -50dB to -6dB for microphone input channels and -30dB to +14dB for line input channels.

5. SIGNAL INPUTS

This mixer provide several connectors for signal input and these connectors allow easy connection. Channels 1~4 are balanced line and microphone input and channel 5~8 are mono line input.

6. TALKOVER SWITCH

All other input signals are muted by the input signal of channel 1 auto-matically when this switch pressed on.

7. PHANTOM POWER SWITCH

The phantom power can be provided to each microphone input for using condenser microphone.

8. EXT.MUTE

Mutes input signals fed to CH1~CH4 muting function by short-circuiting at these terminals.

9. DC 24V INPUT & LINK TERMINAL

If connected to DC 24V. These terminals are provided for the connection of 24V DC power source. 24V DC battery source can be connected to these terminal. The device will supply power to other device by the link output terminal.

10. REMOTE MIC INPUT

The RJ45 connector allows connection for the RWP-4 (desktop remote microphone) for individual zone announcement.



Block Diagram

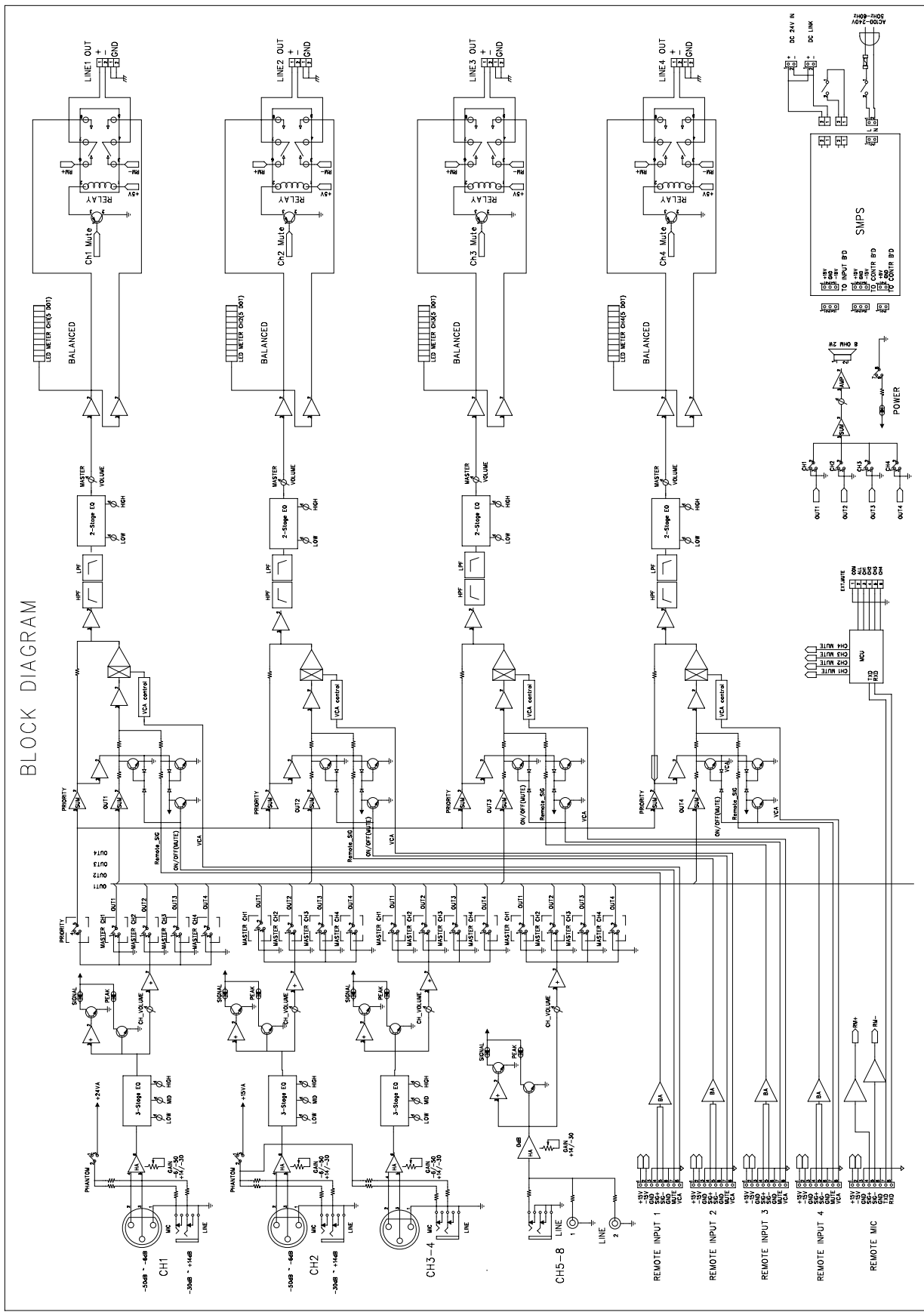

Specifications

Model Name		M804
Rated Output Level / Impedance		0dB / 600 Ω Balanced
Input sensitivity /Impedance	Mic Input	-50dB~ - 6dB / 20KΩ Balanced
	Line Input	-30dB~ +14dB / 20KΩ Balanced
	Remote Input	0dB / 600Ω balanced
Output level / Impedance		0dB / 600Ω balanced
Frequency Response (-1dB)		20Hz - 20kHz
T.H.D		< 0.1%
Crosstalk		>70 dB
Channel		4 CH
Equalization	Input	High : 12 kHz ± 15 dB / Mid : 2.5 kHz ± 15 dB / Low : 80 Hz ± 15 dB
	Output	High : 10 kHz ± 15 dB / Low : 100 Hz ± 15 dB
Hum & Noise		>90 dB
Power Source		AC 100-240 V, 50/60Hz
Weight (Net)		5.7 kg
Dimensions (W x H x D)		420 x 88 x 320mm

*Specifications and design subject to change without notice for improvements.